

# FLEXOR

## RSH Series

Flexor Poland Sp. z o.o.  
ul. Strażacka 4  
95-080 Tuszyn  
Poland  
info@flexor-group.com



### Highlights

- Fully servo-controlled
- Web width up to 440mm
- Shingle stream delivery
- Optional ONE COLOR flexo station
- Re-register / Print to register functionality
- Sheet label production (any size)

[www.flexor-group.com](http://www.flexor-group.com)



## Highlights

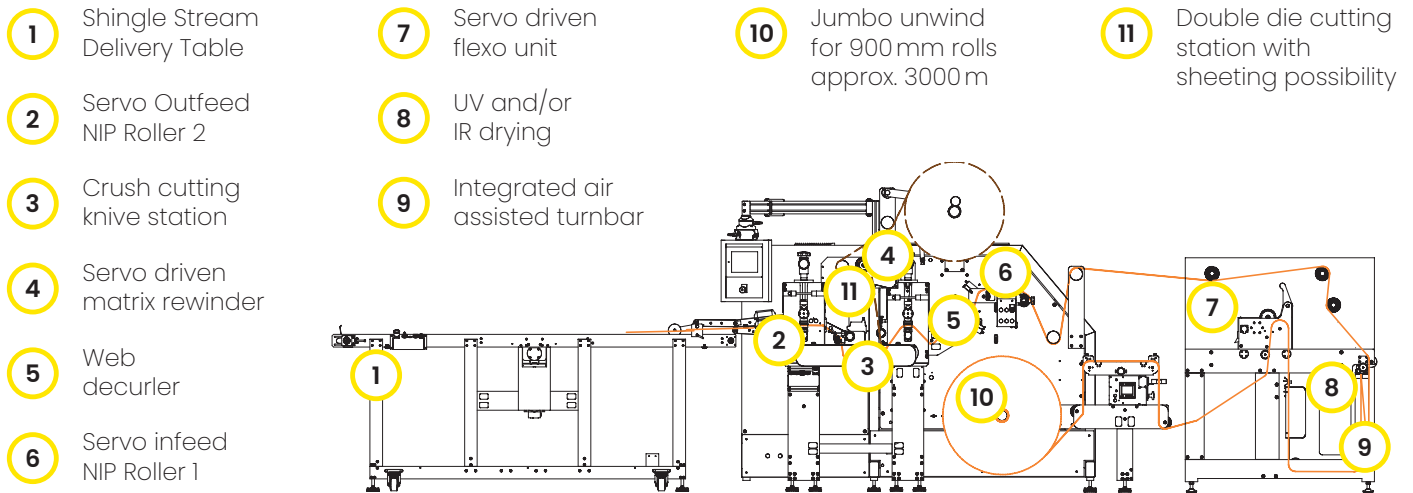

## Technical data

RSH Series	380	440
Max. web width (mm)	380	440
Max. unwind dia. (Jumbo) (mm)	900	900
Max. machine speed (m/min)	150	150
Die cutter: min. / max. cylinder size (mm)	254/610	305/610
Die cutting to register: $\pm 0.2$ mm	Yes	Yes
Dimensions L×W×H (m)	6.6×1.5×2	6.6×1.6×2

## Specifications

- Servo Technology** Latest servo motor technology ensures perfect web tension
- Sheet Label** With a double gearing of 1/8inch and 1/32inch tooth pitch any size sheet can be easily produced
- One Color Flexo** With this servo driven one color flexo unit you can now print sheets and labels and free up more press time
- UV / IR / Corona** Drying by UV, IR or a pretreatment using Corona – with our machine you can now have it all
- Shingle Stream** The shingle stream delivery table will count sheets and batches as well as form batches after a certain amount of sheets
- Matrix Rewinder** High quality servo driven matrix rewinder ensures that even the most difficult matrix can be rewound easily
- Perfect Sheeting** Perfect tension during sheeting process is key to speed and quality hence every FLEXOR slits between two servo driven nips
- Web Decurler** With our innovative web decurler device all sheets produced will be straight with any curvature
- Built-in IQ** 250 job memory, online diagnostics, multi lingual support

